

IDíly k podhlavníku

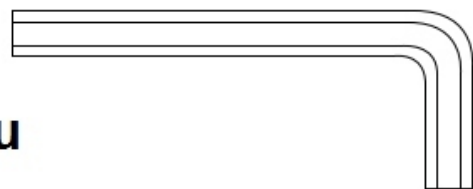

A. Malý imbus

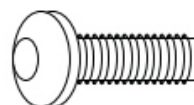

B. M6×12
(2KS)



C. Krytka montážní
plochy podhlavníku

IDíly k opěráku

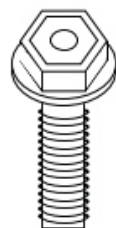

D. M8×20
(3KS)



E. M8×13×2.0
(3KS)



F. M8×20×2.0
(3KS)

IDíly k područkám



G. Větší imbus

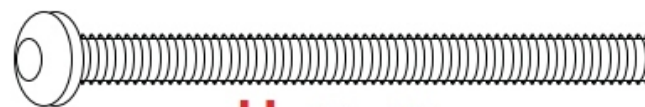

H. M6×55
(2KS)

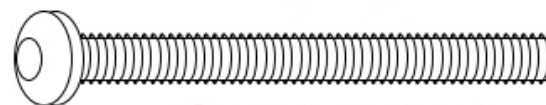

I. M6×45 (2KS)

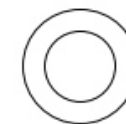

J. M6×16×2.0
(4KS)

01 Montáž kříže a pístu



1. Namontujte kolečka ke kříži

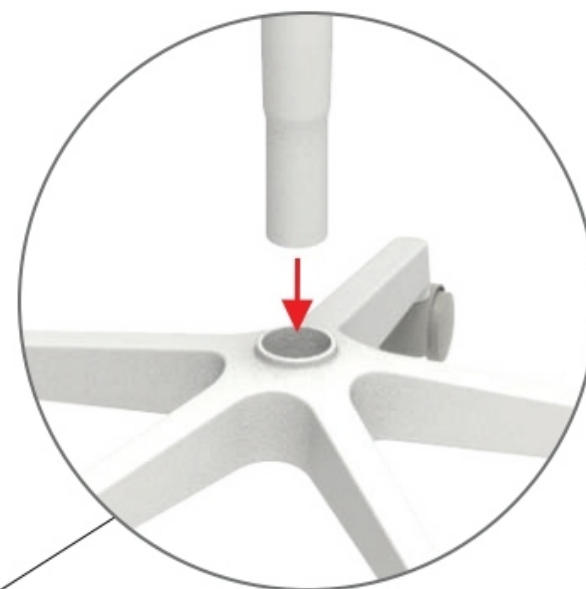

2. Vložte pist do kříže

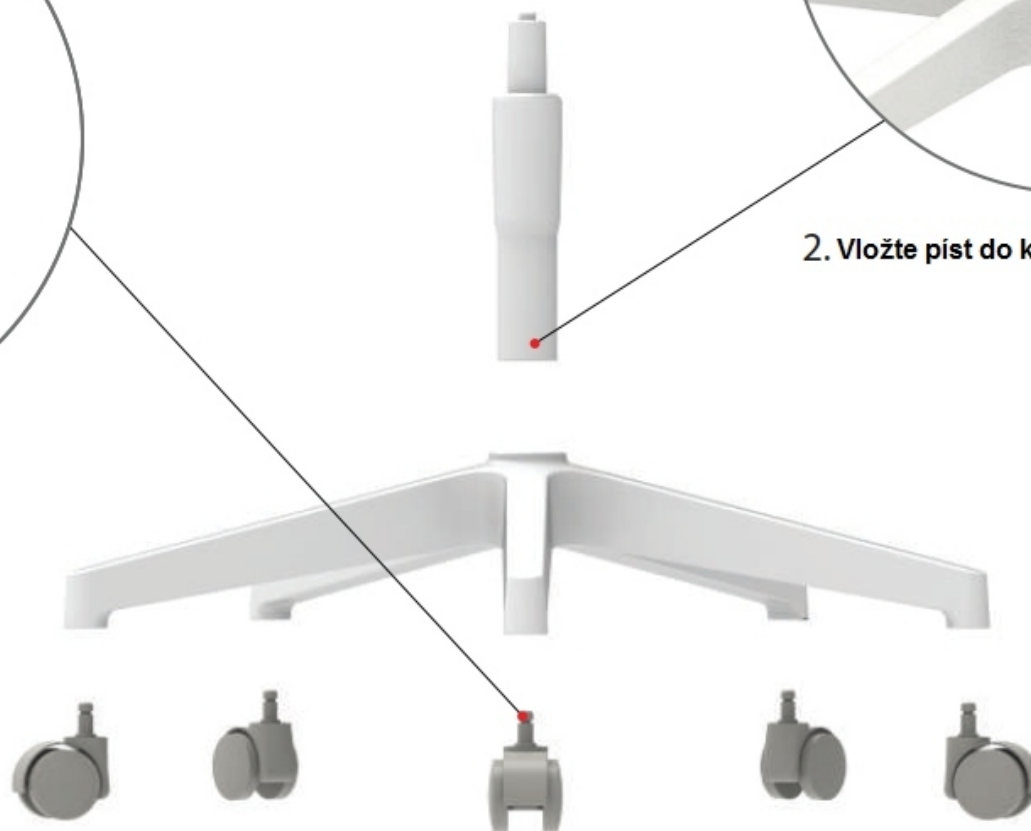

02 Montáž opěráku a područek

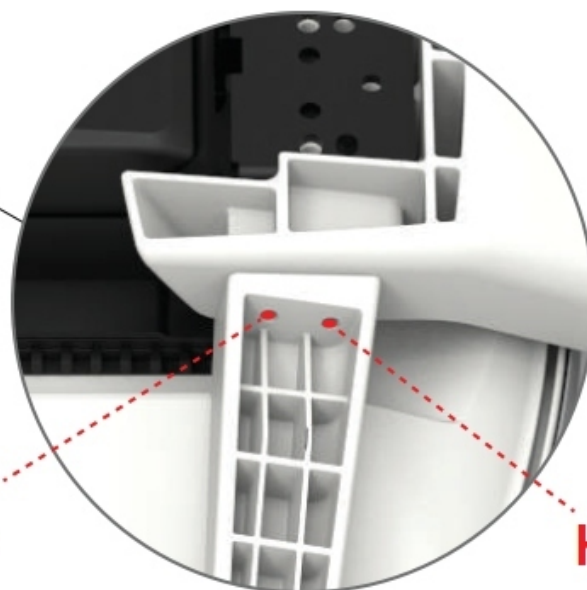
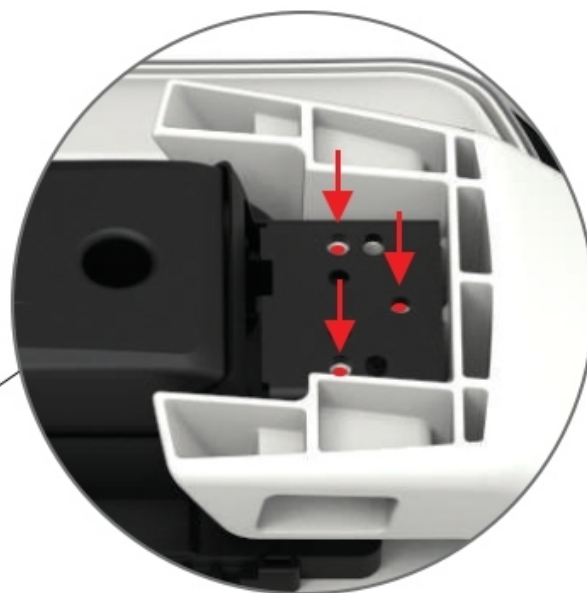

1. Přimontujte opěrák těmito šrouby

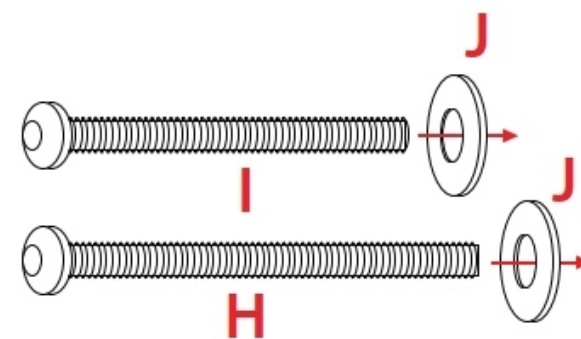
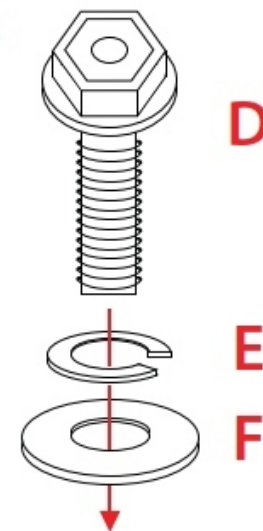

2. Namontujte područky k opěráku šrouby dle obrázku výše

03 Montáž kříže a podhlavníku

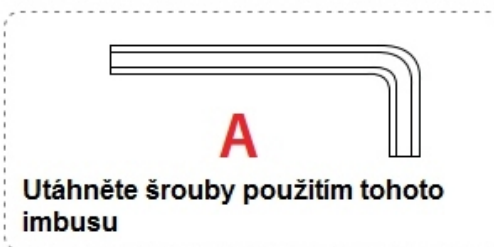

2. Namontujte podhlavník použitím těchto šroubů

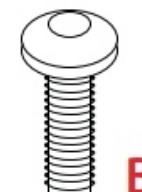

B

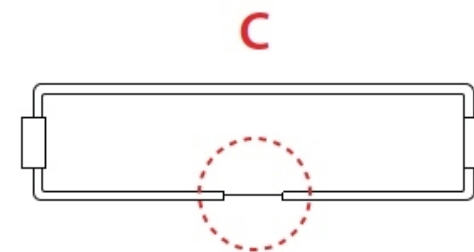

C

1. Dokončete montáž židle spojením těla židle s pístem ve složeném kříži.

3. Zacvakněte krytku montážního prostoru podhlavníku tak, aby otvor na něm mířil směrem dolů.

■ Synchronní mechanismus

Úprava výšky sedáku

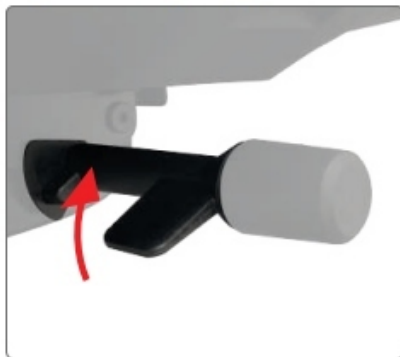

Zamykání opěráku

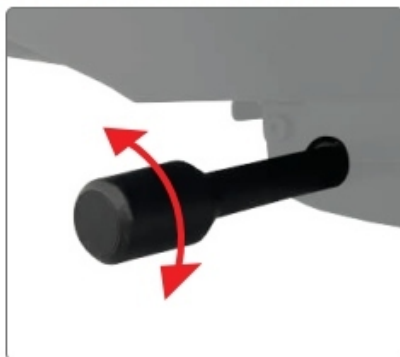

Úprava protitlaku zhoupnutí

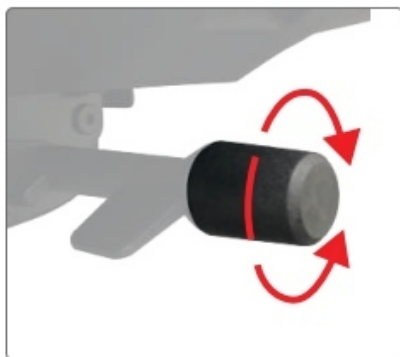

■ Bederní opěrka

Nastavení bederní opěrky

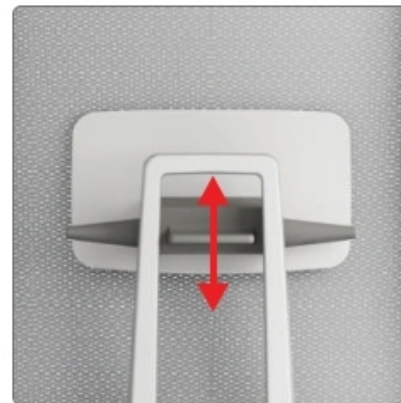

Úprava napětí bederní opěrky



Područky

Úprava výšky područek

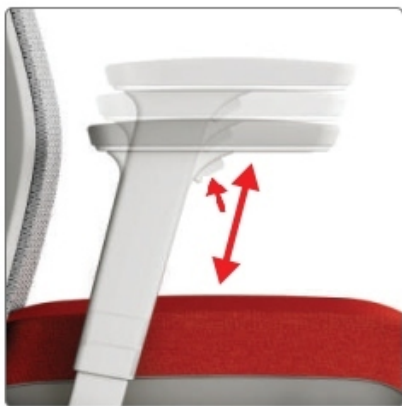

Úprava hlobky a úhlu područek

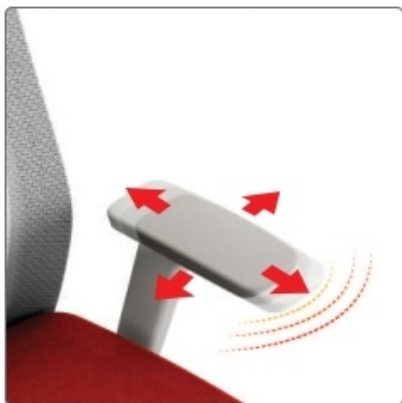

Podhlavník a sedák

Úprava výšky podhlavníku



Úprava hĺoubky sedáku

